



4908 McKenna Ct., Columbus, OH 43221 USA
(614) 876-6345 sales@aircraftextras.com

Installation Guide for the “Header Tank Automatic Fill Relay, model HTAF”

Thank you for purchasing the “Header Tank Automatic Fill Relay” (model: HTAF) manufactured by Aircraft Extras, Inc. The HTAF is a “Smart” Header Tank Pump Relay. This device automatically keeps the aircraft header tank full without over stressing any fuel pumps. A low fuel sensor can be easily mounted in the header tank. When low fuel is detected in the Header Fuel Tank, the HTAF will pump up the header tank for a short time period, then automatically shut the fuel pump off. The HTAF is normally used with a very reliable optical fuel level sensor (optional) that can be easily installed in the header fuel tank. If the user is not able to install a fuel sensor in the header fuel tank, the HTAF can be set up so the pilot may manually activate the timed pumping.

The HTAF can be operated in one of four pre-programmed pumping times. The unit also has a relay output that can be used for a light to indicate when the fuel in the header tank is low. The low fuel relay output is damped so that it does not falsely indicate low fuel in the case of sloshing fuel. The system can be powered by +12V or +24V electrical systems.

SAFETY

(PLEASE READ THIS SECTION CAREFULLY BEFORE PROCEEDING!)

Installing the HTAF is easy and safe as long as you make sure that you do it properly. Please follow these recommended guidelines.

- 1.) Consult your local aviation expert. Discuss the safety aspects of installing anything into or around aircraft fuel tanks.
- 2.) Take precautions to prevent any of the wiring of this system to come in direct contact with the aircraft fuel, even in the event of a fuel tank leak.
- 3.) After the sensor has been installed, seal around the outside and inside of the sensor & tank with Proseal or equivalent fuel tank sealant in order to guarantee no leaks. If a metal sensor nut is utilized, cover it with sealant to prevent corrosion contaminating the tank. This also prevents the nut from backing off.
- 4.) Route the wiring immediately exiting the sensor “up” and then out of the fuel area, and into a safe area. This will prevent the fuel (if a fuel leak should occur) from migrating down the inside of the sensor wiring cable.
- 5.) Seal around the sensor and the sensor exiting cable to guarantee no fuel migrates into the cable in case of a fuel leak.
- 6.) If you are installing this system into a fuel tank that has already contained fuel, consult your local aviation expert on the precautions you should take to prevent a fire or possible explosion during installation.
- 7.) Avoid using tools that will generate sparks or high heat during installation if your fuel tanks have previously contained fuel.
- 8.) Make sure the cable exiting the sensor is brought out, and well away from the fuel tank area before terminating the wires or installing a “quick disconnect” connector of any sort.
- 9.) Make sure that your installation does not leave any debris inside the fuel tank or clog the fuel intake.
- 10.) Install the electronics enclosure well away from any area that may become soaked in fuel. This area should be vented and free of any fuel vapor.
- 11.) Use recommended fusing for the electronics. Refer to all appropriate system wiring & assembly diagrams.
- 12.) Keep any fusing or circuit breakers away from any area that may contain fuel or fuel vapor.

IMPORTANT for +24V OPERATION

The HTAF can be operated with **+24V system power**. In order to do this, a foil on the back of the PC Board ***MUST BE CUT***. Remove the foil section in between these two cuts. If this is not accomplished, it could damage the unit when power is applied. After this is accomplished, you can wire per the connection diagram. The lamp and fuel pump should be designed for 24V operation.

CUT FOIL JUMPER ON BACK OF BOARD HERE FOR +24V OPERATION

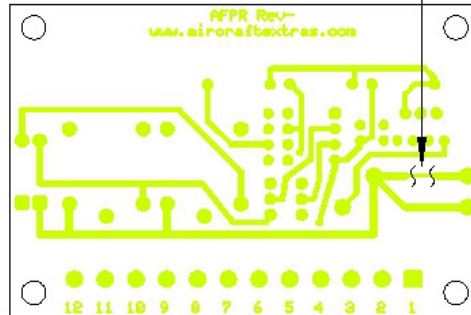

FUEL SENSOR INSTALLATION

WARNING: The installation instructions for installing the Low Fuel Sensors were written for tanks that have not yet had fuel in them. The fuel sensor installation may be a bit tricky if you have already had fuel in your tanks! You should consult your local A&P for safe methods in order to accomplish this. Please read our SAFETY tips!

FUEL SENSOR POSITION

The location of the fuel sensor should be located at the lowest part of the tank. The sensor must also be mounted horizontally. The reason for this is, if the sensor is mounted in another direction, a drop of fluid may remain on the sensor tip not allowing the sensor to detect a no fuel condition. It must be mounted so that the fuel drains off of the sensor tip.

FUEL SENSOR MOUNTING

Drill a hole in the side of the tank appropriate for the sensor. Secure the sensor in the tank using the nut and washer provided. The washer goes on the outside of the tank. Use Proseal (or another approved fuel tank sealant) to seal the sensor so it will not leak. Wire the sensor leads to the electronics. If the wires are not long enough, solder on a longer length of wire. Be sure to electrically insulate the wire junctions and keep them away from any fuel.

FUEL SENSOR MOUNTING WITHOUT THE SENSOR RETAINING NUT

If you cannot get into the tank to secure the sensor retaining nut, here is a suggested mounting method. Drill a hole in the side of the tank appropriate for the sensor. Install the sensor into the hole using the washer between the tank wall and sensor. Fabricate a mounting bracket such that it is secured to the fuel tank or some nearby structure mounted to the tank. Design this bracket so that it firmly presses the rear of the sensor against the fuel tank and locks it into position. Design the bracket so that it is easily removable. Use Proseal (or another approved fuel tank sealant) to seal the sensor so it will not leak. Connect the sensor leads to the electronics. If they are not long enough, solder on a longer length of wire. Be sure to electrically insulate the wire junctions and keep them away from any fuel.

ELECTRONICS ENCLOSURE INSTALLATION

The electronics enclosure was designed to mount almost anywhere. Mounting it near the sensor or fuel pump eliminates the need for running long wires. Keep the enclosure away from extremely high temperatures, areas of excessive vibration or where fuel may be spilled.

SYSTEM WIRING & FUSING

Please follow the wiring diagram provided. We recommend that you size the wiring to the HTAF for your maximum current of the fuel pump. The fuel sensor wires and terminals 3 & 4 can be #18 to #24AWG. For fusing, you should use a circuit breaker or a time delay fuse that is proper for your fuel pump load.

NOT ABLE TO INSTALL A FUEL SENSOR IN HEADER TANK

If the user is not able to install a fuel sensor in the header fuel tank, the HTAF can be set up so the pilot may manually activate the HTAF. This can be accomplished with a normally open switch (NO) connected between terminals 2 and 11. Pressing this switch simulates a low fuel condition starting the HTAF. This switch can be installed on the instrument panel. (NOTE: because the HTAF was designed for a fuel sensor, and it utilizes fuel slosh damping, the user may have to press this switch for several seconds before the pumping starts.

SELECTING A PUMPING TIME

The HTAF can be operated in one of the four possible pre-programmed pumping times. Select one of these time periods below and wire the HTAF according to the diagram.

1 MINUTE Pump Time

PUMPTIME0, HTAF Terminal 3, Connect to battery common.

PUMPTIME1, HTAF Terminal 4, Connect to battery common.

2 MINUTE Pump Time

PUMPTIME 0, HTAF Terminal 3, No connection (OPEN)

PUMPTIME 1, HTAF Terminal 4, Connect to battery common.

3 MINUTE Pump Time

PUMPTIME 0, HTAF Terminal 3, Connect to battery common.

PUMPTIME 1, HTAF Terminal 4, No connection (OPEN)

4 MINUTE Pump Time

PUMPTIME 0, HTAF Terminal 3, No connection (OPEN)

PUMPTIME 1, HTAF Terminal 4, No connection (OPEN)

Enjoy!

AIRCRAFT EXTRAS, Inc.
4908 Mc Kenna Ct.
Columbus, OH 43221
(614) 876-6345
www.aircraftextras.com
e-mail: sales@aircraftextras.com

CHOOSE PUMPING TIME AFTER LOW FUEL HAS BEEN DETECTED.

YOU MAY CHOOSE ONE OF FOUR PRE-PROGRAMMED PUMPING TIMES BY SELECTING WHICH TERMINALS TO CONNECT TO BATTERY COMMON.

- 1 MINUTE PUMPING TIME, PUMPTIME0 (TO BATTERY COMMON), PUMPTIME1 (TO BATTERY COMMON)
- 2 MINUTE PUMPING TIME, PUMPTIME0 (OPEN), PUMPTIME1 (TO BATTERY COMMON)
- 3 MINUTE PUMPING TIME, PUMPTIME0 (TO BATTERY COMMON), PUMPTIME1 (OPEN)
- 4 MINUTE PUMPING TIME, PUMPTIME0 (OPEN), PUMPTIME1 (OPEN)

