



4908 McKenna Ct., Columbus, OH 43221 USA
(614) 876-6345 sales@aircraftextras.com

Installation Guide for the “AE Fuel Guardian”

Thank you for purchasing the “AE Fuel Guardian” manufactured by Aircraft Extras, Inc. This product is a “Low Fuel Level Annunciator” that was designed for aircraft. This system is designed to give the pilot a flashing light warning when a low fuel level occurs. The AE Fuel Guardian also has an audio output when a low level is detected. This output can be used to inject an audio signal into the pilot’s audio system. The system can be powered by +12V or +24V electrical systems.

The system consists of:

Two, Low Fuel Sensors & cable
Two, Instrument Panel Lights
One, Acknowledge/Test Push Button
One, System Electronics Circuit Board.

SPECIAL TOOLS you may need:

#J Drill, .277” dia.
Drill for a 0.47” to 0.50” diameter hole
Unibit to drill a 0.63” dia. hole
Wire Strippers
Diagonal Cutters
Long Nose Pliers

SAFETY

(PLEASE READ THIS SECTION CAREFULLY BEFORE PROCEEDING!)

Installing the AE Fuel Guardian is easy and safe as long as you make sure that you do it properly. Please follow these recommended guidelines.

- 1.) Consult your local aviation expert. Discuss the safety aspects of installing anything into aircraft fuel tanks.
- 2.) Take precautions to prevent any of the wiring of this system to come in direct contact with the aircraft fuel, even during a fuel tank leak. Seal all wiring and sensor items with Proseal or an equivalent fuel tank sealant where shown.
- 3.) After the sensor has been installed, seal around the outside and inside of the sensor & tank with Proseal or equivalent fuel tank sealant in order to guarantee no leaks. If a metal sensor nut is utilized, cover it with sealant to prevent corrosion contaminating the tank.
- 4.) Route the wiring immediately exiting the sensor “up” and then out of the fuel area, and into the fuselage. This will prevent the fuel (if a fuel leak should occur) from migrating down the inside of the sensor wiring cable.
- 5.) Seal around the sensor and the sensor exiting cable to guarantee no fuel migrates into the cable in case of a fuel leak.
- 6.) If you are installing this system into a fuel tank that has already contained fuel, consult your local aviation expert on the precautions you should take to prevent a fire or possible explosion during installation.
- 7.) Avoid using tools that will generate sparks or high heat during installation if your fuel tanks have previously contained fuel.
- 8.) Make sure the cable exiting the sensor is brought out, and well into the fuselage away from the fuel area before terminating the wires or installing a “quick disconnect” connector of any sort.
- 9.) Make sure that your installation does not leave any debris inside the fuel tank or clog the fuel intake.
- 10.) Install the electronics circuit board inside the fuselage area well away from the fuel area. (preferably, behind the instrument panel area)
- 11.) Use recommended fusing for the electronics. Refer to the appropriate system power wiring diagram.
- 12.) Fully test the Low Fuel Warning system. Make sure you know how much fuel is remaining when the light energizes. There are two lights . . . Make sure each light indicates for the correct fuel tank for which it is labeled.
- 13.) Test the audible output if it is utilized. It should be present only when any light is blinking.
- 14.) Ensure proper labeling is affixed to the instrument panel. Make sure that the lights clearly depict the proper quantity of fuel for each tank when it indicates a low level. This should be tested in a level flight attitude, and not while the aircraft is parked at the fuel pump.

INSTRUMENT PANEL LIGHTS & PUSH BUTTON INSTALLATION

The AE Fuel Guardian annunciator lights and push button should be mounted on the instrument panel in plain view of the pilot. A good place for these components are right in front of the pilot's face, just below the instrument panel overhang. NOTE: These lights should be shielded from direct sunlight as they may be more difficult to see. Please note that the maximum thickness of the panel should be 0.15". This distance is limited by the push button switch.

After you have selected a proper mounting location for the components, you will need to drill two holes for the lights, 0.63" (16mm) in diameter. A unibit or similar device should be utilized to drill a clean hole. Please notice that the lights have a little protrusion on the rear. This is used for a key so the lights will not rotate when the rear nut is tightened. It is also used as a guide to keep the lights perpendicular or square to a pre-punched panel during installation. You may decide to drill an appropriate hole, or just simply cut off this protrusion. The choice is up to the builder.

Now you will need to drill the hole for the push button. The hole should be 0.277" or (7mm) in diameter. A "J" drill will suffice.

Install the switch and lights. Affix the proper labeling to each light, according to the low fuel level for each tank.

WARNING LIGHTS - (IMPORTANT)

The warning lights should arrive, already pre-wired. After installation in the instrument panel, the wires should be conditioned or prepared for the vibration created by the aircraft. The wires coming directly out of the light housing are soldered to the housing tabs. These wires may break over time due to vibration if left unattended. The proper way to prevent this, is to surround the terminal, and part of the wire, with a coating of RTV (Silicon Rubber). Coat these leads where they exit from the lamp with a coating of RTV about 1/16" to 1/8" thick. This will prevent the wires from flexing. These wires should also be wire tied to the aircraft chassis to minimize vibration.

+24V OPERATION

This system is normally supplied with 12V light bulbs. For 24V system operation, you will need to purchase 24V light bulbs separately. They are available at www.aircraftextras.com or you can purchase them from another vendor. The part number is: (Manufacturer: EAO, Part #31-1313.1249). Any bulb will work as long as it is 24V, and a standard T 1-3/4 type bulb. For wiring, please follow the diagrams for 24V connection.

FUEL SENSOR INSTALLATION

WARNING: The installation instructions for installing the Low Fuel Sensors were written for tanks that have not yet had fuel in them. The fuel sensor installation may be a bit tricky if you have already had fuel in your tanks! You should consult your local A & P for safe methods in order to do this. See the SAFETY tips!

SENSOR POSITION

Mounting the fuel sensors is really simple, but first, you must give considerable thought to the location of these sensors. In general, the location of these sensors will work best if you locate them near the fuel pick-up points in your tanks. In 98% of all cases, this is also the lowest point in your tanks.

One consideration to mounting your sensors, is how the sensors will operate during normal flight attitudes with near low fuel levels. Refer to diagram #1 and #2.

In diagram #1, the low fuel sensor is mounted on the inside wall (see diagram 3 & 4) of the fuel tank. In this mounting position, the sensor will indicate “fuel level OK” in a shallow climb, level flight, and a shallow descent. In the descent position, notice that the fuel sensor will indicate OK, as where the fuel pick-up point comes close to sucking air instead of fuel. This is OK as long as the pilot is aware of these factors. Please be aware that most fuel level indicators never indicate correctly unless you are in level flight either.

In diagram #2, the low fuel sensor is again, mounted on the inside wall of the fuel tank, only a little further aft. In this mounting position, the sensor will indicate “fuel level OK” in level flight and a climb position. In the descent position, notice that the fuel sensor will indicate LOW fuel, and the fuel pick-up point comes close to sucking air instead of fuel. This is also OK. The system will now have different characteristics than diagram #1. This is also OK as long as the pilot is aware of these factors.

Using diagram #1

GOOD POINT

The benefit of this diagram is that it will closely indicate the same amount of fuel left in the tank in all three aircraft attitudes.

BAD POINT

The bad point is that you may be caught in a nose down situation with the fuel level indicating OK, and the fuel pick-up point coming close to sucking air instead of fuel.

Using diagram #2

GOOD POINT

The benefit of this scheme is that the sensor will detect when the fuel pick-up will be dangerously close to sucking air instead of fuel in most all aircraft attitudes.

BAD POINT

A low fuel level indication will not indicate to the pilot that there is a given quantity of fuel in the tanks for all flight attitudes shown. It will vary with aircraft attitude more than diagram #1.

In summary, the situations above were exaggerated a bit in order to make a point. Ultimately, the builder will be the one who will choose which position is best for a particular aircraft and pilot. Be sure you pick a position for the sensor that will not put you in jeopardy when in flight. It is also up to the builder to characterize this system after it is installed and to affix any markings to the instrument panel if necessary for normal flight. Another thing to keep in mind or use for thought: . . . When a fuel tank is very low in fuel, most fuel tank systems were designed to use all useable fuel during a climb. This is why the tank pick-up lines are usually in the rear of most tanks.

SENSOR HEIGHT

The sensor's height above the bottom of your fuel tank, depends upon the low fuel alarm level that you choose. In order to select an appropriate Low Fuel Alarm Level for your installation, you must assume that your aircraft will measure this low fuel level properly in level flight. Normal aircraft banking should not matter much if you use coordinated turns.

Refer to diagram #5. In order to select a height for your low fuel level sensor, you must first decide on the position of the sensor discussed in previous text. Once this has been determined, you should put your fuel tank in a level flight attitude. NOTE: (A close approximation of the level flight attitude will also suffice, since you should actually test when the lights turn off as you initially add fuel to your tanks after installation.)

Refer to diagram #5. After putting your empty fuel tank in a level flight attitude, attach a clear tube to the tank's fuel drain point. The tube should be open at the end. Secure the end of the tube to the side of your fuel tank, in the approximate position for your sensor. Fill the tank with liquid equivalent to the amount that you would like the fuel sensor to sense a low fuel level. Mark a line on the tank at the top of the liquid level in the tube. Remove the liquid from the tank.

The sensor thread is a 1/4NPT which requires no nut. It is a standard pipe thread. You will have to fabricate a bung with the appropriate female thread on the side of the tank. In order to do this, you may use a scrap piece of 1/4" to 3/8" thick aluminum and simply drill and tap a 1/4NPT thread in it. Drill a hole in the tank about (0.47" to 0.50" diameter) or purchase the appropriate and drill the appropriate hole. Follow the directions described in the sensor installation drawing located at the end of this manual.

NOTE: Please use water as this liquid for safety. Allow the tank to dry completely before putting fuel in it.

NOTE: The optical fuel sensor should not be mounted so that the ball or tip of the sensor is pointing down. This will allow a possible drip of fuel to remain on the tip of the sensor. The sensor may not detect a low fuel level if this is the case. In most cases, the sensor should be installed on a tank side wall.

ELECTRONICS INSTALLATION

The electronics circuit board should be located inside the fuselage away from extremely high or low temperatures. It should also be shielded from any person from accidentally shorting out the electronics when troubleshooting or during normal operation. It will be up to the builder to fabricate an appropriate shield for this board.

It is mounted by four stand-offs. You can use these stand-offs to mount the board to a panel. You should use four, #6-32 screws. They should be 1/4" to 3/8" in length depending upon your panel thickness.

SYSTEM WIRING

OK, it's time to wire! There are three diagrams included in the AE Fuel Guardian installation kit. One diagram is the sensor wiring diagram, the other two are the power wiring diagrams. The sensor diagram applies to all installations. Please follow the proper power diagram for your aircraft depending upon if your aircraft system is powered by +12 volts, or +24 volts.

FUNCTION

How does the unit function? Well, it's rather simple. The AE Fuel Guardian has two inputs (optical fuel level sensors) and two outputs (annunciator lights). Each sensor and associated light operates independently of each other. At power-up, the unit goes to a self test mode. The two lights should blink alternately for three seconds letting the pilot know that the system is OK. After this period, the unit will function normally. At this time, if the tip of the sensor is covered with fuel, it's associated light will not be on. At the moment the sensor detects that the fuel is not covering the tip of the sensor, its associated light will blink at a one second interval signaling the pilot of a low fuel level. Once the pilot sees the blinking light, the pilot then momentarily presses the Acknowledge/Test push button. This action is the pilot acknowledging that the low fuel level exists. It stops the light from blinking and then it remains on continuous. At this time, the light will remain on (latched). NOTE: In this mode, if the fuel level were to rise above the sensor tip due to a

different flight attitude or fuel cross feeding from another tank, the light would not go out. It would remain on.

The AE Fuel guardian was designed to function as described above because the pilot would be acknowledging flashing lights forever when the fuel level was bouncing around at this low level point. This would quickly become annoying to the pilot. If the pilot knows that this low level alarm was a false alarm, all he or she has to do, is press the Acknowledge/Test button once more. The AE Fuel Guardian will then reset the system and read the tank again continuously. If the fuel level is above the sensor, the light will go out. If the fuel level is still below the sensor, the light will begin immediately blinking again, signaling a low fuel level.

It is possible for the AE Fuel Guardian to activate indicating a low fuel level due to an aircraft's unusual attitude during flight. Normally will not happen unless the tanks are very low or the aircraft is involved in aerobatic flight. If this is the case, the pilot can acknowledge the low fuel level and allow the lights to remain on until the flight is in a more normal flight attitude. When a normal flight attitude is achieved, the pilot may again press the Acknowledge/Test push button and make the alarm lights go out.

PUSH to TEST

If you hold the Acknowledge/Test push button in for three seconds, both lights should come on solid. When you let go of the button, the unit will signal you by alternately blinking the two lights. When this happens, this means that the self test is complete and OK.

AUDIO OUTPUT

The AE Fuel Guardian has an audio output that sounds while the lights are flashing. This output can be wired into your aircraft's audio panel to further warn the pilot of a low fuel level. The audio level volume can be adjusted by turning the one turn potentiometer located on the AE Fuel Guardian's circuit board. The output cannot be used to power a speaker directly.

BE CAUTIONED

The AE Fuel Guardian is a great and reliable product that provides the pilot with a little extra insurance! . . . but . . . Keep in mind, that this product should never be utilized for the only method of detecting your aircraft's fuel levels. The pilot should use a visual reference of the fuel level before a flight, as well as in flight fuel gauges to ensure a trouble free flight.

Enjoy!

AIRCRAFT EXTRAS, Inc.
4908 Mc Kenna Ct.
Columbus, OH 43221
(614) 876-6345
www.aircraftextras.com
e-mail: sales@aircraftextras.com

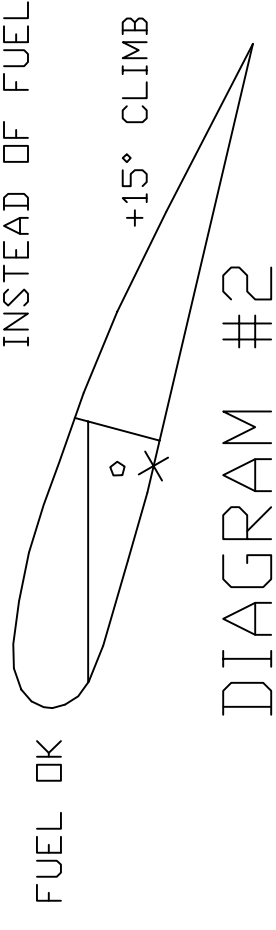
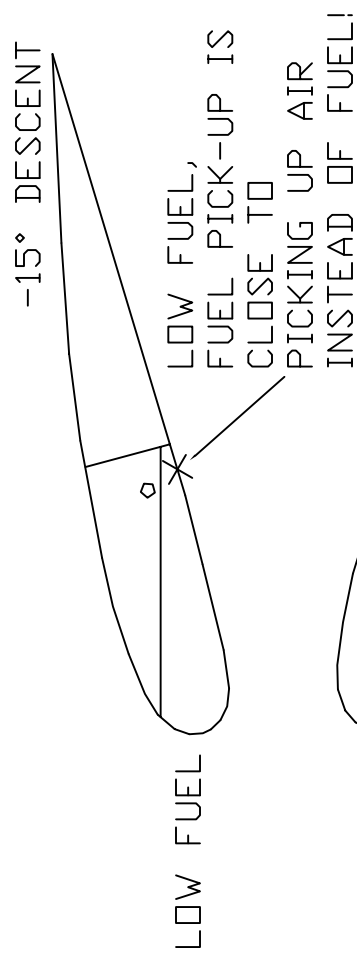
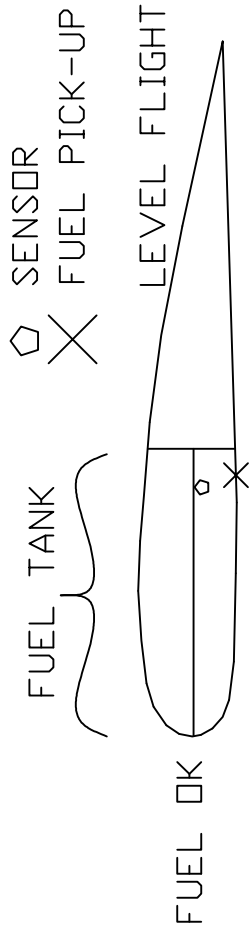
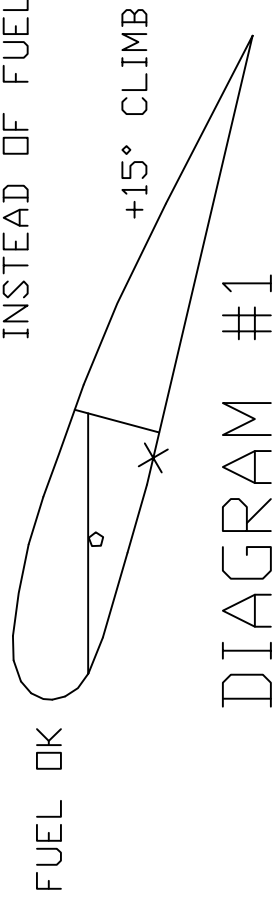
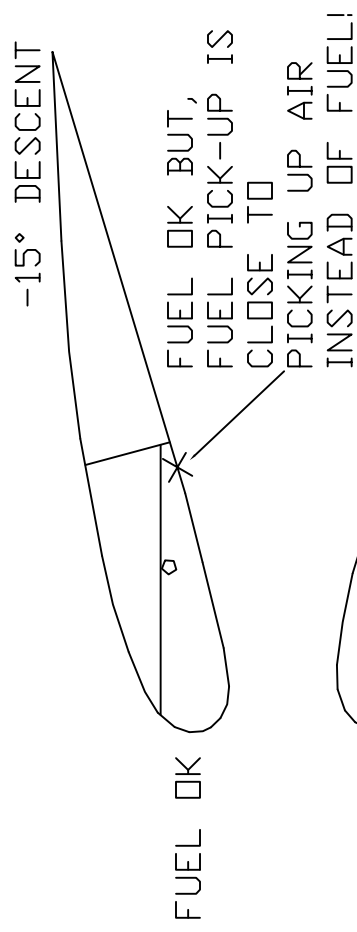
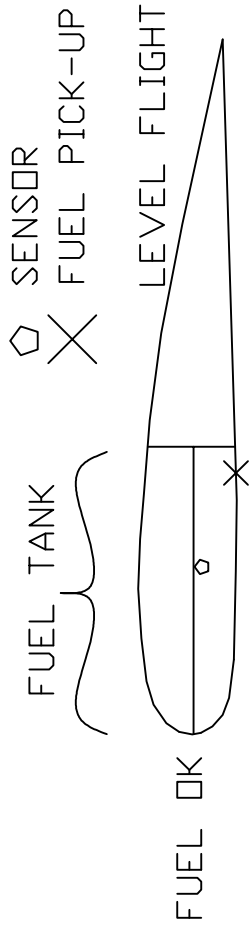

DIAGRAM #3

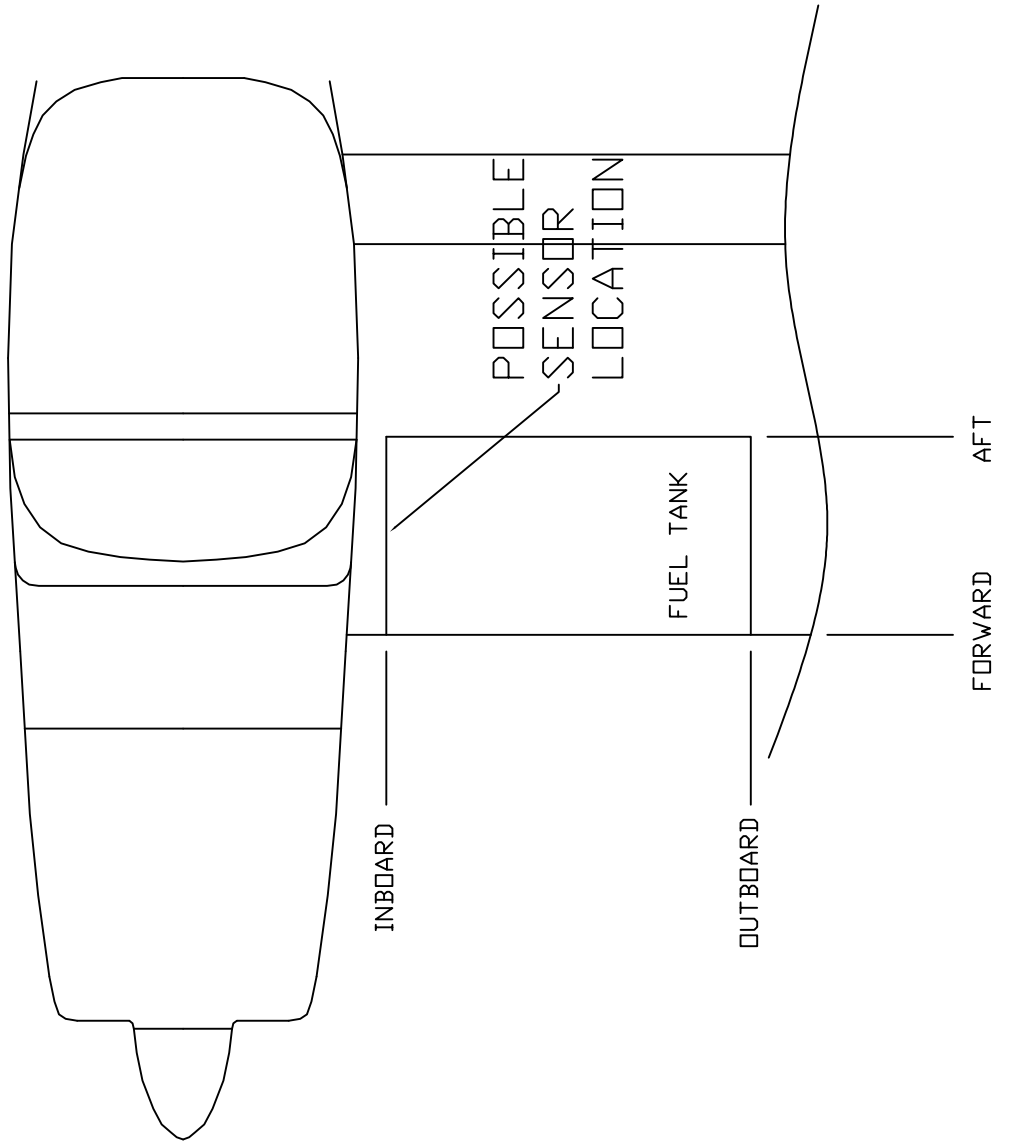
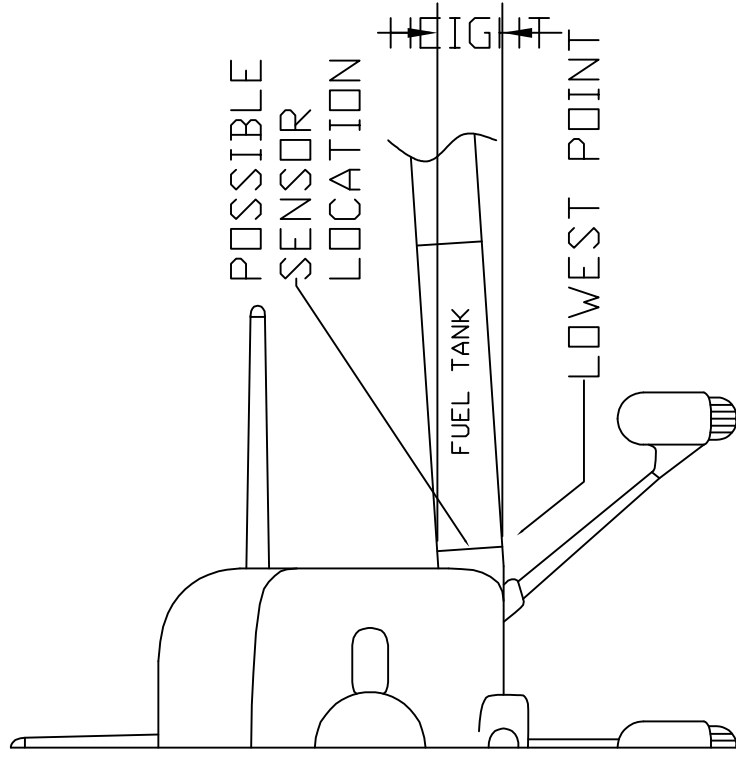

DIAGRAM #4



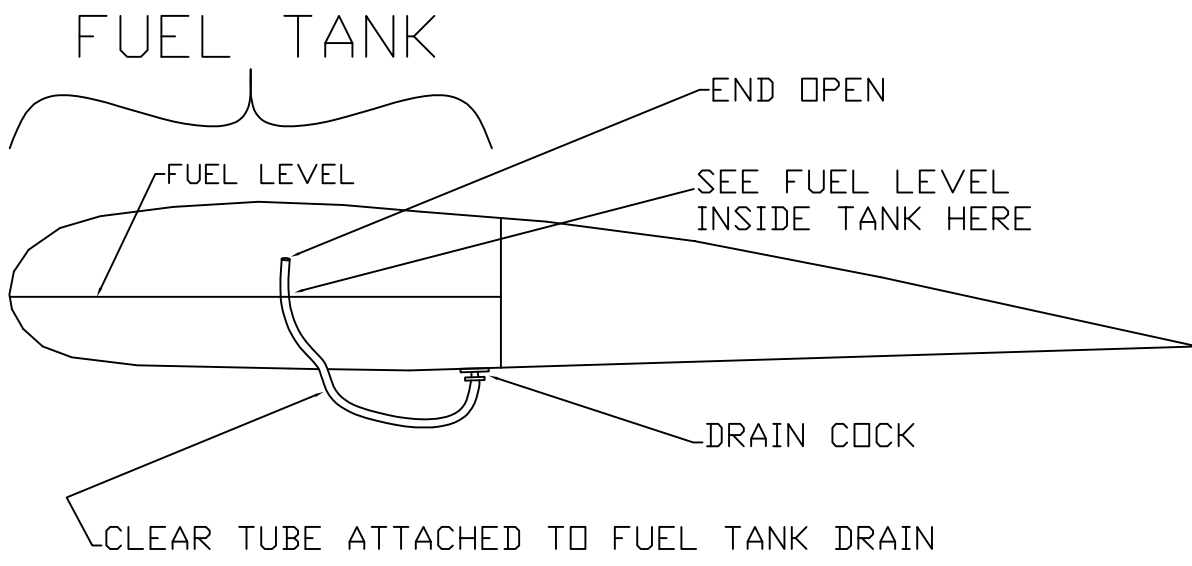
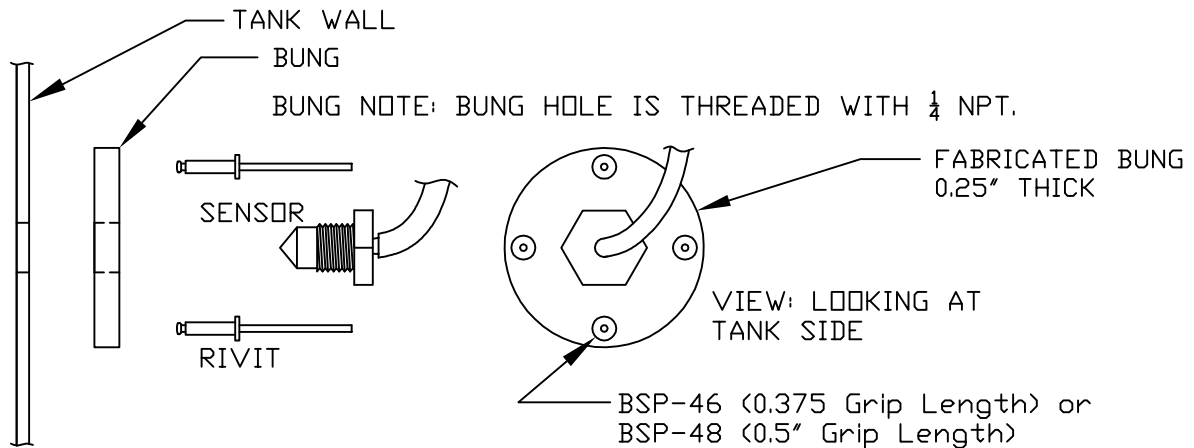

DIAGRAM #5

NOTE:

THE EXAMPLE BELOW IS ONLY AN EXAMPLE OF WHAT OTHERS DID TO INSTALL THEIR FUEL SENSOR. IT IS UP TO THE INDIVIDUAL BUILDER TO DETERMINE WHAT WILL BE THE BEST SOLUTION FOR THEIR PROJECT.

WARNING! DO NOT DEFACE THE TIP OF THIS SENSOR OR GET SEALER ON IT. THIS MAY RENDER THE SENSOR INOPERABLE. SEE THE SENSOR SPEC SHEET FOR MORE DETAILS.



- 1.) THE SENSOR NEEDS TO BE MOUNTED HORIZONTALLY OR (VERTICALLY, POINTING UP ONLY) SO THAT A DROP OF FUEL DOES NOT ACCUMULATE ON THE TIP OF THE SENSOR, OTHERWISE IT WILL STILL SENSE IT IS IN FUEL.
- 2.) FABRICATE A 2" DIA. BUNG AS DEPICTED ABOVE OR SIMILAR. CREATE A 1/4 NPT THREADED HOLE FOR THE SENSOR. DRILL 4 to 6 APPROPRIATE HOLES FOR THE RIVETS IN THE BUNG AND THE TANK WALL. (USUALLY 0.125" DIA.)
- 3.) APPLY PROSEAL OR AN EQUIVALENT FUEL TANK SEALER BETWEEN BUNG AND TANK WALL BEFORE RIVETING TO PREVENT LEAKS.
- 4.) RIVET BUNG TO WALL. BLIND RIVET TYPES SHOULD WORK FINE. ENSURE THAT YOU APPLY PROSEAL ON THE RIVET HEADS BEFORE RIVETING TO SEAL THE HOLES.
- 5.) SCREW IN SENSOR (PAY ATTENTION TO THE SPEC SHEET TORQUE SPECIFICATIONS!) TIGHTENING TORQUE (13.26 in.-lbs. or 1.5Nm) IT IS NOT IMPORTANT THAT THE SENSOR HEX NUT BOTTOMS OUT ON THE FEMALE FITTING HOLE.

NOTE:

IF YOU CHOOSE TO USE FUEL LUBE ON THE THREADS BEFORE SCREWING IT IN, WE CANNOT GUARANTEE THAT YOU SHOULD USE THE SAME TORQUE SPECIFICATIONS. IT MAY BE TOO MUCH FORCE. FUEL LUBE MIGHT HELP THE THREADS TO SEAL BETTER, BUT IT WILL BE EASIER FIT. DO NOT GET FUEL LUBE ON THE SENSOR TIP IF YOU CHOOSE TO USE FUEL LUBE. THE SENSOR MAY NOT WORK.

- 6.) USE "A SMALL DAB" OF PROSEAL ON THE SIDE OF THE SENSOR HEX HEAD AND THE BUNG SO THAT THE SENSOR WILL NOT BACK OUT. YOU MAY WANT TO ALSO FABRICATE ANOTHER MECHANICAL DEVICE TO GUARANTEE THAT THE SENSOR WILL STAY IN.
- 7.) SECURE THE SENSOR WIRES WITH TY-WRAPS LOCALLY SO THAT THE WIRES WILL NOT BE PULLED OUT OF THE SENSOR.

**Aircraft
Extras Inc.**

FUEL SENSOR INSTALLATION EXAMPLE 10-17-2024.dwg

ALL dimensions in inches.

R.A.M. 10/17/2024

Aircraft Extras

SENSOR WIRING DIAGRAM for +12V or +24V SYSTEMS

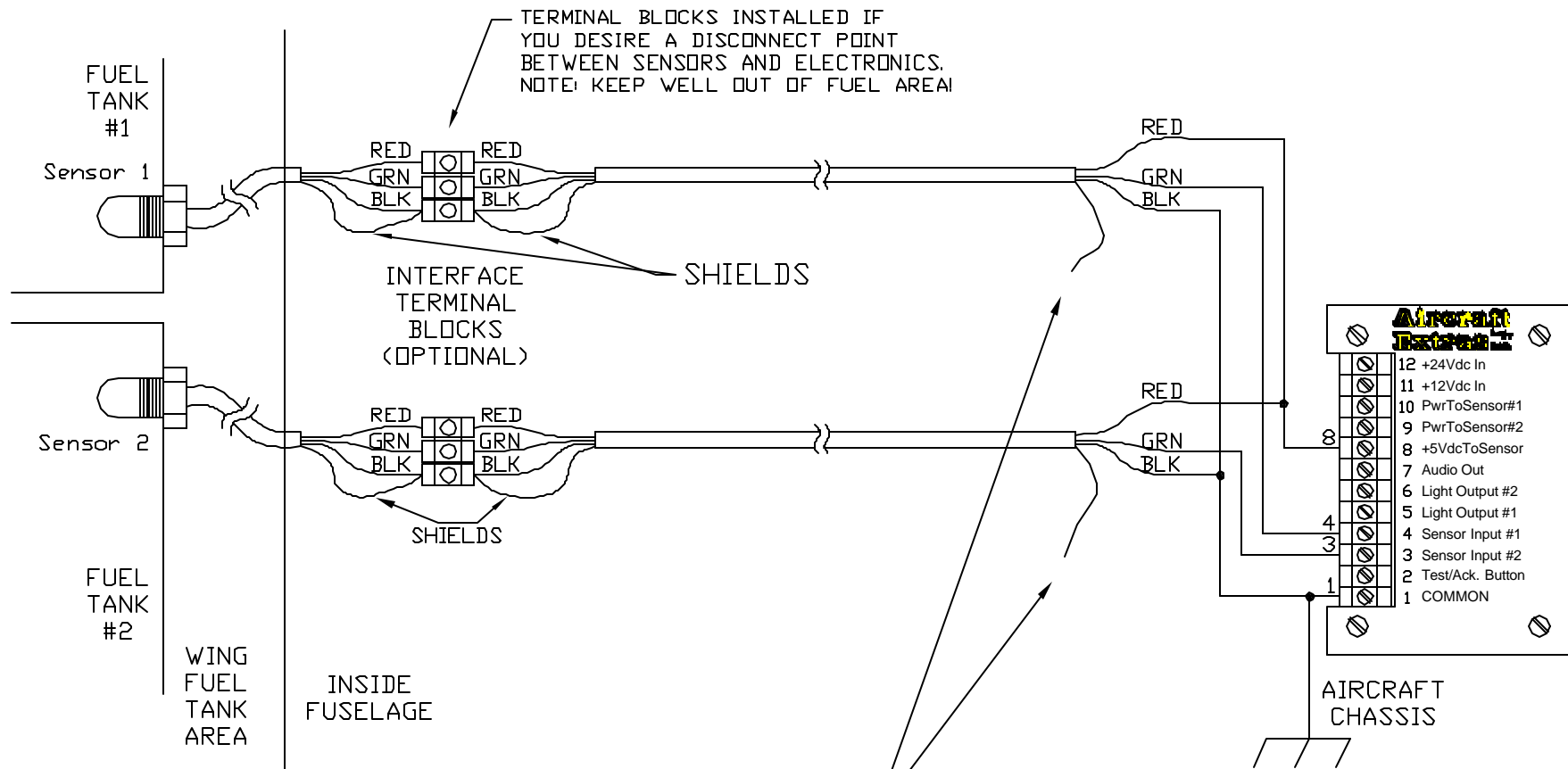

CONNECT SHIELDS OF SENSOR CABLES TO AIRCRAFT CHASSIS, NEAR CIRCUIT BOARD ELECTRONICS.

NOTE: MOUNT THE ELECTRONICS CIRCUIT BOARD IN THE FUSELAGE, WELL AWAY FROM THE FUEL AREA AND HIGH TEMPERATURES.

AIRCRAFT EXTRAS, INC.
 www.aircraftextras.com
 AE FUEL GUARDIAN SENSOR WIRING DIAGRAM
 AEFgschemSen, 1/18/06, Rev-

LIGHTS, PUSH BUTTON, & POWER WIRING for (+12V NEGATIVE GROUND SYSTEMS ONLY)

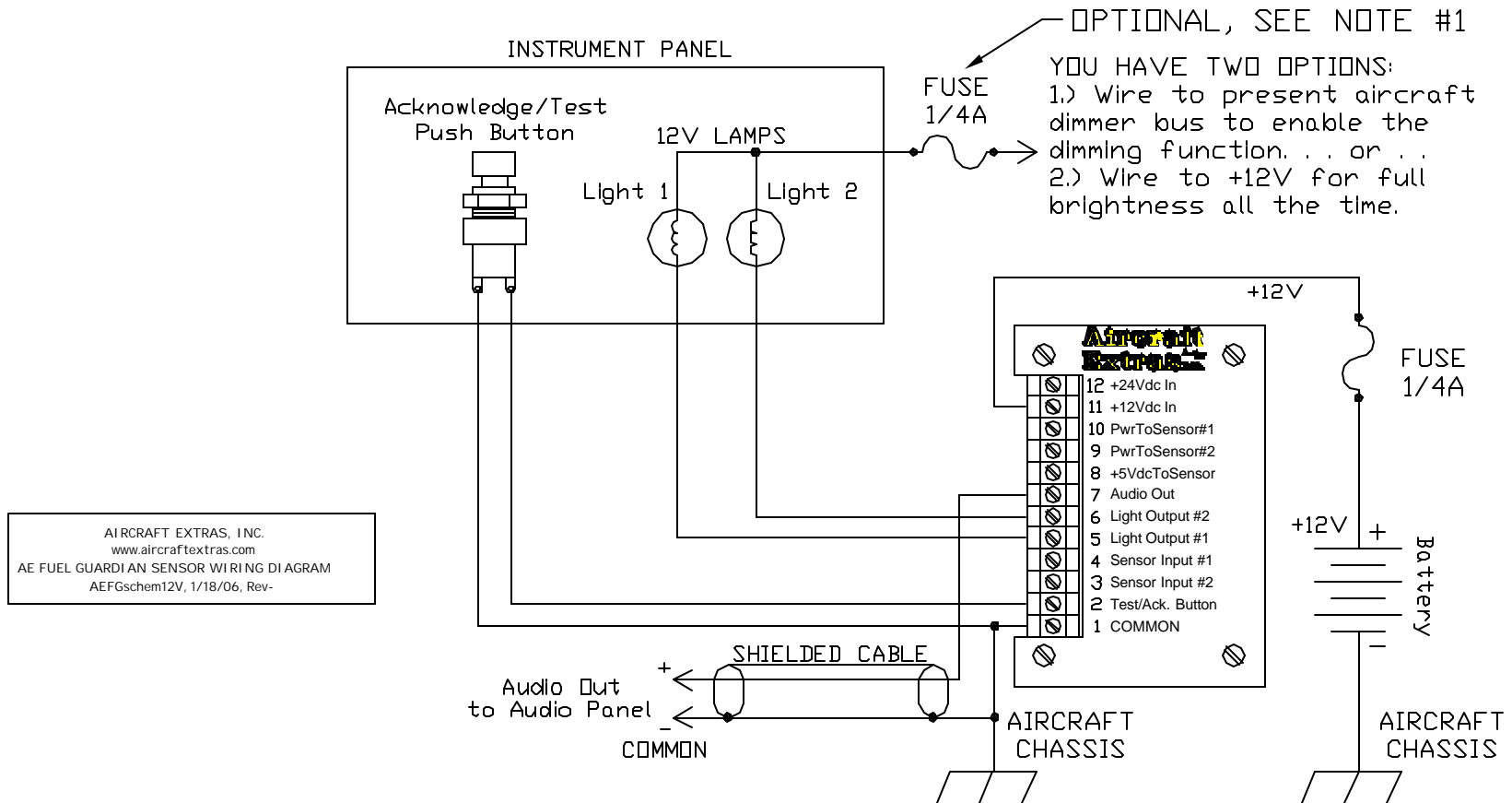

AIRCRAFT EXTRAS, INC.
www.aircraftextras.com
AE FUEL GUARDIAN SENSOR WIRING DIAGRAM
AEFGschem12V, 1/18/06, Rev-

CONNECT SHIELDS OF SENSOR CABLES TO AIRCRAFT CHASSIS, NEAR CIRCUIT BOARD ELECTRONICS.

NOTE #1: THIS FUSE IS RECOMMENDED IF YOU DO NOT WIRE THE LIGHTS INTO A DIMMER BUS THAT IS ALREADY FUSED.

NOTE #2: MOUNT THE ELECTRONICS CIRCUIT BOARD IN THE FUSELAGE, WELL AWAY FROM THE FUEL AREA AND HIGH TEMPERATURES.

LIGHTS, PUSH BUTTON, & POWER WIRING for (+24V NEGATIVE GROUND SYSTEMS ONLY)

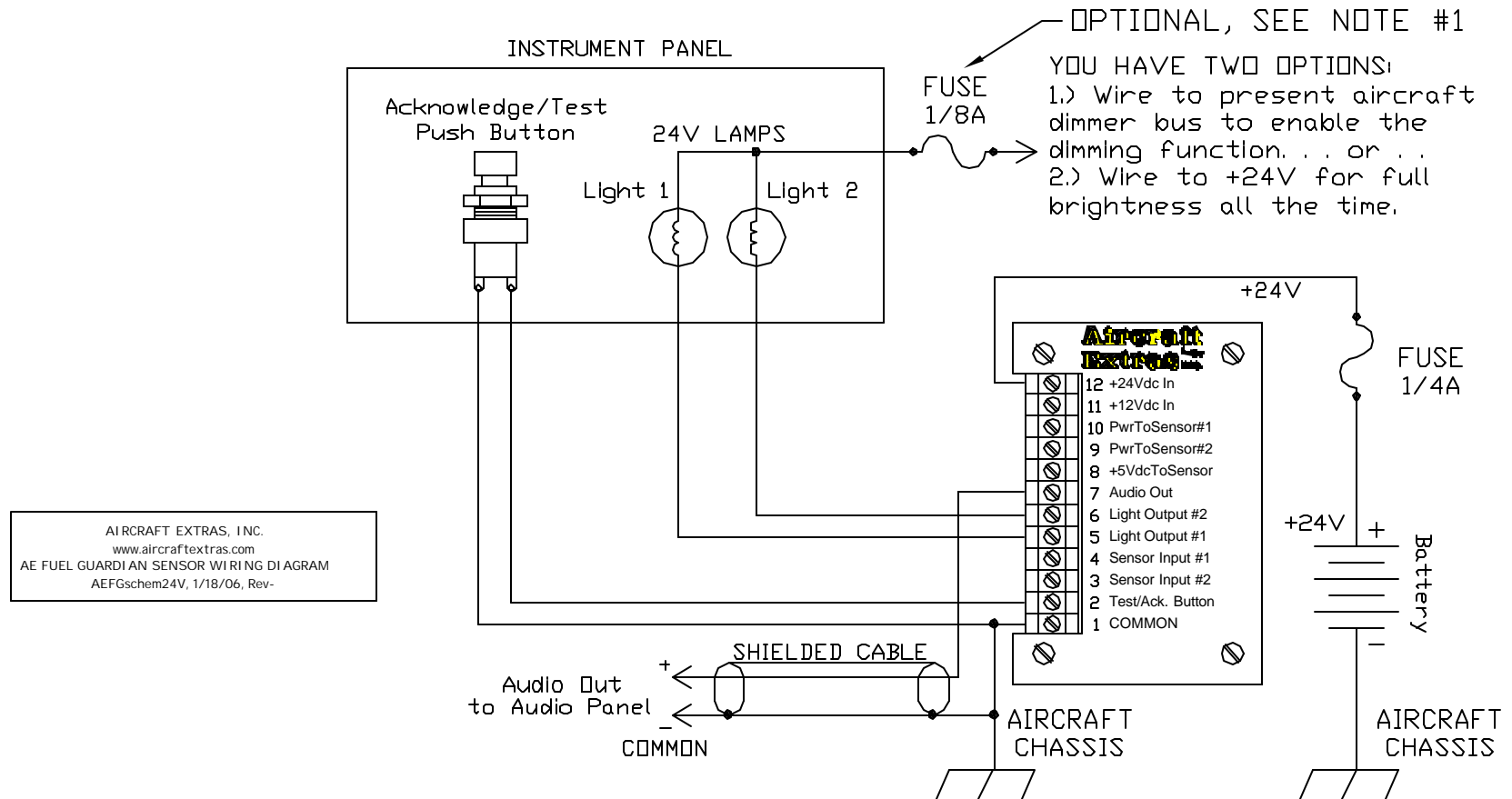

AIRCRAFT EXTRAS, INC.
www.aircraftextras.com
AE FUEL GUARDIAN SENSOR WIRING DIAGRAM
AEFGschem24V, 1/18/06, Rev-

CONNECT SHIELDS OF SENSOR CABLES TO AIRCRAFT CHASSIS, NEAR CIRCUIT BOARD ELECTRONICS.

NOTE #1: THIS FUSE IS RECOMMENDED IF YOU DO NOT WIRE THE LIGHTS INTO A DIMMER BUS THAT IS ALREADY FUSED.

NOTE #2: MOUNT THE ELECTRONICS CIRCUIT BOARD IN THE FUSELAGE, WELL AWAY FROM THE FUEL AREA AND HIGH TEMPERATURES.