



4908 McKenna Ct., Columbus, Ohio, 43221 USA

(614) 876-6345

www.aircraftextras.com sales@aircraftextras.com

INSTALLATION MANUAL

FPS-Plus Rev-L, 12/20/2024

FPS-Plus

THANK YOU! . . . for purchasing the FPS-Plus system from Aircraft Extras, Inc. Please review **ALL** instructions thoroughly before you install and program the FPS-Plus. Please adhere to ALL safety precautions.

DESCRIPTION

The FPS-Plus system is an automatic flap positioning system with automatic elevator trim compensation. It can be used in the manual positioning mode, or one of several automatic modes. In the fully automatic mode, a “short touch” of the flap button, positions the flaps, and the elevator trim tab. The elevator trim is automatically positioned with each flap stop position, so that the elevator control pressure is minimized for the pilot. It is all done automatically, once the unit has been installed and programmed. A one second or more touch of the flaps, commands the flaps to go to either the full up or full down position.

COMPATIBLE SERVO MOTOR ASSEMBLY TYPES for the FPS-Plus

The FPS-Plus system was designed to operate with flap and elevator trim motors that are "clutch driven". In other words, when these motors are connected to the flap and elevator trim control surfaces, the motors cannot be over driven to damage the control surfaces or linkage components. Most aircraft actuator motor assemblies have clutches or end stops built in them so that, . . . for instance, when they reach the end mechanical flap stop, the clutch slips so no damage is done to the flap or flap linkage.

NON-CLUTCH DRIVEN SERVO MOTOR ASSEMBLIES can also be made to work.

If your flap and/or elevator trim motor assemblies are not clutch driven, please refer to the alternate schematic published on our web and in this manual, for wiring.

INSTALLATION

ENCLOSURE INSTALLATION

The FPS-Plus enclosure should be installed inside the cockpit area of the aircraft, away from excessive vibration and high temperatures. The enclosure should be secured to a “metal panel” by the two holes provided on the bottom flanges of the enclosure. The enclosure should then be electrically connected to the aircraft chassis common. In the case of a fiberglass aircraft, you should run a separate wire to ground the chassis of the FPS-Plus. The enclosure should be mounted so that the LED can be seen for initial programming only. There is no need after that.

PROGRAMMING BUTTON INSTALLATION

It is recommended to install the programming button on the instrument panel somewhere it will not be accidentally bumped. This switch allows the pilot to fine tune or adjust the elevator trim compensation settings if your aircraft balance changes significantly. This may easily be done in flight. If need be, the FPS-Plus can also be reprogrammed using this same switch.

WIRING

Review the wiring diagram included, along with the “Standard Aircraft Wiring Practices Guide”. Wires depicted on the schematic that have a larger thickness, (the motor current wiring to the power source) should be sized for the maximum amperage for that motor circuit. An absolute maximum motor current of 10A is allowed for the FPS-Plus. All other wires are low amperage wires and can be #24AWG to #18AWG.

TO MINIMIZE ELECTRICAL and/or RF INTERFERENCE

Avoid routing wiring for the FPS-Plus, in the same vicinity of your radio transmitter or other antenna cabling or the strobe light systems. This also includes devices such as the transponder, ADS-B or other types of RF transmitters, or devices that put transients on the +12V or +24V power bus.

POSITION SENSOR NOTES:

USING: RAY-ALLEN POSITION SENSORS: If you are using a Ray-Allen model POS-5, POS-7, or POS-12 position sensor, the wiper of their pot is the green wire. This should be connected to the "Flap Position In" (FPS-Plus terminal 8). The orange and blue wires are the end positions of the pot. Connect the orange wire to "+5V Output" (FPS-Plus terminal 4), the blue to "common" (FPS-Plus terminal 3). Measure the voltages mentioned above. If, per chance, you measure these voltages, and the voltages seem to be reversed from the full up and the full down positions, simply swap the orange and blue wires.

FPS-Plus POSITION INDICATOR OUTPUTS & JUMPER SETTINGS

FPS-Plus TRIM & FLAP POSITION INDICATOR OUTPUTS

There are several types of position indicators on the market today. Unfortunately, they all seem use different voltages for their inputs, and have different input impedance. (**DO NOT connect your position indicators directly to the position sensors.**) this may load the sensor and cause inaccurate readings. The FPS-Plus provides two outputs to drive your position indicators. Both outputs have two different output scalings. One output scaling option is (0.83V to 4.93V) for the RayAllen Inc. RP4 LED indicator. The second output scaling option is (0 to 6V). This one is for any EFIS type system or the RayAllen Inc. RP2 Analog indicator. The proper output scaling can easily be changed at installation by using jumpers on the back of the FPS-Plus . . . Again, set for it for (0-6V) for most EFIS type system indicators. If you cannot utilize one of these two scalings for your indicators, please contact Aircraft Extras, Inc. for information on how to make these outputs work for your application.

NOTE: Just for reference, the older FPS-Plus was scaled for (0.1V to 1.2V) for the RayAllen Inc. RP3 LED indicator, which is not used now.

SELECTING the PROPER JUMPER POSITIONS for your TRIM & FLAP POSITION OUTPUTS

Having read the previous paragraph, you are now ready to select the correct jumper settings for your FPS-Plus. These jumper positions are located on the back of the FPS-Plus. Refer to the diagram included in this manual to select the correct jumper settings for your application.

PRE-TESTING the FPS-Plus AFTER WIRING and INSTALLATION

PRE-TESTING the POSITION SENSOR DIRECTION

Whether your flap and elevator trim position sensors are separate or part of your motor assemblies, you will have to ensure they are connected up properly. Please pay particular attention to the direction of travel, the polarity of the signal output and how they are connected. You can test these voltages when the potentiometers are connected to the FPS-Plus, and the unit is powered on. Using the FPS-Plus in "Mode 1", you can actuate the flaps and elevator trim motors, and see this voltage changing.

For the Flaps, when the potentiometer (position sensor) is connected to the FPS-Plus, it should be installed so that the "full up flap position" measures approximately 2.2Vdc to 4.95Vdc into the FPS-Plus system. The "full down flap position" should measure approximately 0.05V to 0.6Vdc. These measurements are taken from terminals #8 "Flap Position In" to terminal #3 "common".

PLEASE NOTE: OTHER SERVOS with INTERNAL POSITION SENSORS

The above paragraph applies to the potentiometers connected to +5V and full travel of the pot is observed.

As of (about) the year 2023, there have been several servo motors sold by Vansaircraft, PHaviation and others that are a bit different. They have incorporated an internal position sensor in their flap servo motors. Even when these position sensors are powered by our +5V, the output does not go from (0 to +5V). They may typically go from (0 to 2.4V or so) These voltages could also vary depending on the servo and length. These servos will work with the FPS-Plus just fine, with some restrictions.

Situation #1: Configuring the FPS-Plus flap position output (Terminal #11) for an "Analog or EFIS" position indicator.

If you configure the FPS-Plus output for the "Analog or EFIS" output, the FPS position output will not be (0 to 6V). It may be something like (0 to 3.6V) or so. This output on terminal #11 should still be usable into an EFIS system for flap position, depending upon the maximum voltage your EFIS recognizes as a full scale input. See your EFIS manual.

Situation #2: Configuring the FPS-Plus flap position output (Terminal 11) for an "RP4 indicator".

If you are using a RP4 position sensor, the output will not go to the full up position. Contact us for a resolve for this situation.

Situation #3: Configuring the FPS-Plus elevator trim position output (Terminal #12) for an "Analog or EFIS"

Same as situation #1 above.

Situation #4: Configuring the FPS-Plus elevator trim position output (Terminal #12) for an "RP4 indicator"

Same as situation #2 above.

PRE-TESTING the MOTOR ASSEMBLY DIRECTION

To ensure that the motor assemblies function properly with the FPS-Plus, you must connect them so they move the control surfaces in the proper direction. Pay particular attention to the output wiring of the FPS-Plus. When the wire that is connected to terminal 15, goes to +12V, the flap motor should move the flaps up. (The wire at terminal 16 will stay at common or ground potential)

When the wire that is connected to terminal 17, goes to +12V, the elevator trim motor should move the elevator trim in the "elevator up trim direction". (The wire at terminal 18 will stay at common or ground potential) (NOTE: In this case, it will move the elevator trim control surface in a down direction, provided you have a conventional trim system on your elevator trailing edge.) Using the FPS-Plus in "Mode 1", you can actuate the flaps and elevator trim motors to see if the motors respond to the proper direction.

SYSTEM OPERATION OVERVIEW

SYSTEM OPERATING MODES

There are, four modes of basic operation, two modes for user programming, and one intermediate mode. The intermediate mode is used for toggling from mode to mode during system set-up only. This system is designed to operate in one of the four operating modes while in the air. Before commissioning your aircraft, you should choose one of the five operating modes listed below for aircraft operation (1, 2, 3, 4, or 6). There is no need for you to change operating modes during any flight.

When the FPS-Plus is on, the LED will be blinking, denoting what mode it is in. (For example, for mode 4, the LED will blink 4 times then stop for a short time, . . . then repeat that process)

MODE 1 - (Manual flap operation only)

Flap moves only when flap button is pressed. You must keep holding the button for the flap to move.

MODE 2 - (Manual flap operation, with associated elevator trim following)

Flap moves only when flap button is pressed. You must hold the button down for the flap to move.

Elevator trim moves with associated flap position. (if previously programmed in mode 6)

This mode is a little unique in that the elevator trim will move proportionally as the flap moves up and down. In other words, the flap and elevator trim move proportionally as the flap button is held.

MODE 3 - (Automatic flap mode, moves from programmed flap stop to programmed flap stop) (No elevator trim movement)

Flap moves from programmed flap stop to flap stop. One press less than 1 second (Short Press) begins the movement, up or down. Hold the flap button for more than 1 second (Long Press), and the flap will go all the way to its end stop. The direction will be towards the button pressed, flap up, or flap down. If the flap is moving, to stop it, simply press the opposite command. The flap movement will stop.

MODE 4 - (Automatic flap mode, moves from programmed flap stop to programmed flap stop, with associated elevator trim following)

Flap moves from programmed flap stop to flap stop. One press less than 1 second (Short Press) begins the movement, up or down. Hold the flap button for more than 1 second (Long Press), and the flap will go all the way to its end stop. The direction will be towards the button pressed, flap up, or flap down. The elevator trim moves to its associated flap position, if previously programmed in mode 6. If the flap is moving, to stop it, simply press the opposite command. The flap and elevator trim movement will stop.

NOTE: If the flap movement has already stopped, and the elevator trim is still in motion, there is no way to stop the elevator trim motion. It will continue until it reaches its goal. You can however, give the flap another command to move, and then command the flap in the opposite direction. This will stop the flap and elevator trim movement immediately.

MODE 5 - (Program flap stops)

Operation is the same as in mode 1, except that you can erase and program intermediate flap stops. Erasing flap stops also erases all elevator trim positions.

MODE 6 - (Program associated elevator trim positions) (also approved for flight for readjusting associated trim positions)

Operation is the same as in mode 4, except that you can erase and reprogram associated elevator trim positions for every flap stop. *(NOTE: This mode can be used in flight operation to store new elevator trim positions associated with each flap setting during flight. To take full advantage of all of the FPS-Plus features, this mode should be used.)*

“MODE CHANGE” MODE

In this mode, you will not be able to move any control surfaces with the FPS-Plus. The only thing you can do, is change modes with the program push button. You are in this mode when the LED is blinking YELLOW.

(MODE FUNCTIONS BEFORE PROGRAMMING)

NOTE: Before you program the FPS-Plus, the normal operating modes (1-4) will function as follows:

Mode 1 - Full operation as described above

Mode 2 - This mode will operate exactly like mode 1 before programming.

Mode 3 - Full operation as described above (except - the only positions that will be recognized, are flap full up, and full down)

Mode 4 - This mode will operate exactly like mode 3 before programming.

MANUAL CONTROL OVER AUTOMATIC ELEVATOR TRIM ADJUSTMENTS

The FPS-Plus automatically controls the position of the elevator trim in modes 2, 4 and 6. Even though you have programmed the elevator trim for all flap positions, you may want to tweak, or manually adjust the trim from time to time. This is permissible, however; it must be done more than 2 seconds after all automatic elevator trim movements have stopped. Otherwise, . . . the elevator trim will still be in the automatic adjustment mode and your manual adjustment efforts will not succeed.

MOTOR ZERO SPEED SENSING

When the FPS-Plus commands a motor to move, and it senses that the motor is at or near zero speed, the FPS-Plus will stop the output command to move that particular motor within 1 second. This typically happens if the flap is bound up, the flap is at the end of its travel, or the motor or mechanical linkage is defective. This is a built-in safety feature for your aircraft.

PROGRAMMING BUTTON OPERATION

This button allows you to be able to fine tune or adjust your elevator trim compensation settings if your aircraft balance changes significantly. In order for the switch to function in this manner, you will need to operate your FPS-Plus in Mode 6. No other mode will allow this.

The FPS-Plus was designed so that it is easy for the pilot to store a new elevator trim position in flight, by simply pressing one button. While this feature of the FPS-Plus may not be needed for most two seat aircraft, it may be desired for aircraft of 4 seats or more if the aircraft balance changes from flight to flight significantly. To readjust the FPS-Plus to a new flight load, for each flap setting, simply adjust your elevator trim manually, then press the programming button. A new elevator trim position will be stored for that flap position. The FPS-Plus will automatically adjust the elevator trim for each flap setting thereafter. In most cases aircraft flight loads will have to change significantly before the pilot needs to put in new elevator trim values.

PROGRAMMING

There are two modes that you must program, in order to take full advantage of the FPS-Plus features. These two modes are modes 5 & 6. In mode 5 you can program your flap positions or “flap stops”. In mode 6, you can program your associated elevator trim positions for each flap stop that you just programmed in mode 5. Reading further will detail how this is accomplished.

CHANGING MODES

The first thing that you need to do, is learn how to change operating modes of the FPS-Plus. **This should be done only when the aircraft is on the ground, and parked.** If you did not choose to install a programming switch on your instrument panel, a program push button (normally open switch) should be temporarily installed between terminals 5 and 3. See the connection diagram. After the unit has been successfully programmed, this button should be removed if you haven't previously chosen to install it on your instrument panel.

To change modes of operation, simply make sure there is no power to the FPS-Plus unit. Depress the program button. Keep the program button depressed, and then, turn on power to the FPS-Plus. Keep the button pressed until the LED on the unit starts blinking RED, rapidly. Now, release the button. Notice that the RED LED, will blink YELLOW, indicating that the FPS-Plus is in the "Mode Change" mode. The number of yellow blinks will indicate your present mode number. (For example, for mode 4, the LED will blink 4 times then stop for a short time, . . . then repeat that process) Now, to change the mode, simply press and release the program button once, to advance to the next mode. Notice that the number of LED blinks changes every time that you press the program button. Do this until the LED counts, match the mode that you desire. After you have reached your desired mode, turn the unit off. When you power back up, (without depressing the program button) you will be in the mode you just selected. The unit will respond by blinking your mode number in RED, not YELLOW. Keep in mind, if the LED blinks YELLOW, the only thing you can do is change modes. You have to power down, and then back up again to be in your desired mode.

FLAP POSITION PROGRAMMING (Mode 5)

Programming of the flaps should be done only when the aircraft is on the ground, and parked. If you did not choose to install a programming switch on your instrument panel, a program push button (normally open switch) should be temporarily installed between terminals 5 and 3.

In order to program the intermediate flap stops, you will need to put the unit in mode 5. Follow the previous instructions given in "Changing Modes" to change to mode 5. Make sure the LED color is "RED", and blinking 5 times before proceeding.

Starting up in Mode 5

NOTE: This is the flap programming mode. Powering up the FPS-Plus in mode 5, erases ALL previously programmed flap stops and elevator trim positions. Another way to ensure that they were all erased, is to depress and hold the program button in for 5 seconds or more after power up. The LED will turn GREEN temporarily, then blink RED very rapidly, letting you know that all previously programmed flap stops and elevator trim stops have been erased. Now, release the program button. You may begin programming your flap stops.

Programming the flap stops

Just as a reminder;

- 1.) All intermediate flap stops have to be programmed. (It can be done in any order)**
- 2.) DO NOT program the full up and full down flap stop positions!** The FPS-Plus will sense these automatically.

Using the flap up button, position the flap so it is in its "full up" position. Remove your hand from the flap button. Now, pressing the flap down button, move the flap down to the first intermediate flap position you choose. Now, momentarily press the program button (approx. 0.5 to 1 seconds). You will note that the LED will turn GREEN while the program button is depressed, indicating that you have stored the first flap position. Press the "flap down" button again until you reach your next desired flap stop.

Repeat this process for as many flap stops as desired, until you reach your last intermediate flap stop (8 maximum). **DO NOT** program the full down flap position. After all intermediate flap stops have been programmed, turn the unit off. Change to mode 6. Test the flaps to see that you have programmed them properly by momentarily pressing the flap button up or down. If the flap stops are not where you desire, repeat the flap programming steps. NOTE: If your flaps do not go all the way up, or down, you may have installed the position potentiometer incorrectly.

ELEVATOR TRIM POSITION PROGRAMMING (Mode 6)

Before you can program the associated elevator trim values, you must have first, programmed your intermediate flap stop positions in mode 5. Programming of the elevator trim (Mode 6) will be accomplished when the aircraft is in the air. This procedure will be detailed in the flight testing section.

FLIGHT TESTING

JUST TO KEEP YOU ALL SAFE!

We feel that it is the responsibility of Aircraft Extras, Inc. to protect all pilots. We have to assume that there will be all skill levels of aircraft builders and pilots using our systems. This being the case, we have to make the following recommendations to keep all of you safe during your flight testing. After all, you are using this system to automatically alter your aircraft's flight configuration.

- 1.) Before flight, you should have permanently installed the FPS-Plus system and programmed all flap stops utilizing mode 5.**

- 2.) **Before flight, operate the FPS-Plus in Mode 6. Move the flaps from flap stop to flap stop. Note the position of the elevator trim. If it is not in the neutral position for any flap position, move the elevator trim manually, then press the program button to store it. Do this for all flap stops, including full up and down. Doing this will ensure that your elevator trim will be in a flight neutral position for every flap stop before you program your desired positions in flight.**
- 3.) **Do not flight test the FPS-Plus for the first time, unless you are at least 4000 AGL in altitude and you are familiar with the aircraft, flight characteristics, and all emergency procedures.**
- 4.) **Make sure you know how to override the automatic adjustments of the flap and elevator trim made by the FPS-Plus in case of emergency. Make sure you know how to turn the FPS-Plus off, and to take over manual control of the flaps and elevator trim.**
- 5.) **Before you fly, be sure that you test the FPS-Plus on the ground while;
keying up each of the transmitting devices aboard the aircraft,
operating the strobe systems of the aircraft,
operating the transponder or ADS-B. (unit transmitting),
operating any other electrical apparatus that may interfere with the operation of the FPS-Plus,
. . . . and no abnormal behavior of the flap system is noted.**
- 6.) **Ensure that all installed switches are working properly, including your manual control switches.**
- 7.) **For initial flight testing, DO NOT actuate the flaps in the air unless you are below a speed that will accept full flap travel.**

If all pre-testing was satisfactory, and there was no abnormal operation, you may proceed.

Before you take flight, put the FPS-Plus in mode 6. Make sure that the LED is flashing 6 times and is RED. Test the operation of the flaps. Ensure that ALL elevator trim positions are in a neutral position for each flap stop, including full up and full down. If all is OK, you may take-off and climb to 4000 AGL or some safe altitude.

First, Test the Flaps in the Air

Before proceeding with flap programming, test the flap control in the air, full up to full down. Once you are satisfied, you can proceed.

Elevator Trim in Level Flight

Now it is time for elevator trim programming! **NOTE: You will program an associated elevator trim value for every flap position, (even the full up and full down positions.)** While flying at a normal level cruise speed, and the flaps are fully retracted, manually adjust the elevator trim where desired. (This means level flight where there is no stick pressure (up or down) or where you can let go of the stick or yoke and the aircraft remains in level flight) This is usually done at your normal cruise attitude configuration. After you have the elevator trim adjusted, press the program button once. You may not see the GREEN LED light when you press the button, because you have installed the unit under the instrument panel. That is OK though. The green LED will light denoting that this position has been programmed. If there is some doubt, it won't hurt if you press the button again using the same flap position. It will just store the trim position again. (NOTE: Do not press the button for more than 5 seconds or all elevator trim settings will be erased!!)

First notch of flaps down

Now, if you desire for your elevator trim to be adjusted for your landing configuration with the first notch of flaps, you will have to put your aircraft in this simulated flight mode. Slow the plane down. Momentarily press the FPS-Plus flap switch down, when you are ready to go one notch down. The flaps should respond by moving down to the next lower flap position and stopping. If your airspeed and attitude is correct for your landing simulation, adjust the elevator trim so that it is correct for your new flight attitude. After you have the elevator trim adjusted, press the program button once again. Again you may not see the GREEN LED light when you press the button, because you have installed the unit under the instrument panel. Again, that is OK. The GREEN LED will light denoting that this next position has been programmed.

Repeat the above step for every flap position, even the full down position. Simulate your desired flight attitudes with each position. Flight speeds and flap positions can be the same as used for your normal landings. When you are finished, all positions should be programmed. Now, you can see if your programming works the way you programmed it. Here's how.

Testing while in Mode 6

If you leave the FPS-Plus in Mode 6 after programming it, the programmed elevator trim position will automatically follow all associated flap positions. In other words, when you move the flap to a new position, the elevator trim position will follow the appropriate flap position IF you were successful in programming that position. Continue flying the aircraft, and move the flap up and down in different flight configurations. Test to see that you have the proper elevator trim position programmed for all flap positions. If you do not, and desire to program that position again, you may! Simply readjust the elevator trim manually, and momentarily depress the program button again. The new elevator trim position should then be stored in memory on top of the old value correcting the situation.

ELEVATOR TRIM COMMAND UNDERSTANDING

If the flap is re-positioned, the FPS-Plus will also command the elevator trim motor to move. The automatic adjustment of the elevator trim may take a bit more time to get where it needs to be. This may be due to the slower motor used for the elevator trim control. This being the case, after the flap stops moving, you might find yourself trying to manually adjust the elevator trim before the FPS-Plus stops its automatic movement. If this is the case, there are two things that will happen.

- 1.) If you pressed the elevator trim button in the opposite direction for less than 2 seconds, and then let go, the motor will stop for the time you have the button pressed, and continue on to move towards its previous goal.
- 2.) If you press the elevator trim button in the opposite direction for more than 2 seconds, and then let go, the motor will stop for the time you have the button pressed. After a period of 2 seconds of pressing the button you will have manual control. The elevator trim motor will start moving toward your manual command.

In general, you should let the elevator trim motor stop for at least 2 seconds before trying to adjust it manually.

Finished Programming Mode 6

After you are satisfied that the elevator trim has been programmed properly, land the plane, park, and engine off. You may now change the mode of the FPS-Plus to one of the flyable modes. These are modes 1, 2, 3, 4, or 6. It is your choice.

MISCELANEOUS

EMERGENCY PROCEDURES

Be prepared! Make sure that you review what needs to be done in case of a failure of the FPS-Plus in flight. Put the procedures that you create, in the aircraft manual. Create and display in the aircraft, any applicable pla cards, warnings, labels, or cautions if applicable. After all, you are using this system to automatically alter your aircraft's flight configuration.

SOFTWARE

The FPS-Plus is micro-controller based. If there are any safety issues or up-dates, we will attempt to contact you and advise you how to get the latest up-dates. We will also put a notice up on our web site. Please keep us informed as to your latest address, or please visit our web site regularly to review any up-dates on this product. (web www.aircraftextras.com) (e-mail: sales@aircraftextras.com) Other features may become available for this product as well.

GOOD LUCK, have FUN, and please FLY with SAFETY!

(Manual: FPS-Plus Rev-L, 12/20/2024)

SCHEMATIC (FPS-Plus for +12V Systems)

- NOTES:
- 1) THICKER LINES DENOTE HIGHER CURRENT PATH FOR MOTORS & CHASSIS GROUND. SIZE WIRE FOR 10A MAX. #14AWG. ALL OTHER WIRES CAN BE #24AWG.
 - 2) THESE TWO SWITCHES OPERATE INDEPENDENTLY EVEN THOUGH THEY MAY BE IN ONE HOUSING. (Example: RayAllen's RSI or their STICK GRIP switches) SWITCHES ARE [Single Pole, Double Throw, ON-NONE-(ON), Momentary] SEE OUR SWITCH DOCUMENTATION SHEET FOR SUBSTITUTING HAT SWITCHES, RELAYS, OR OTHER SWITCHES.

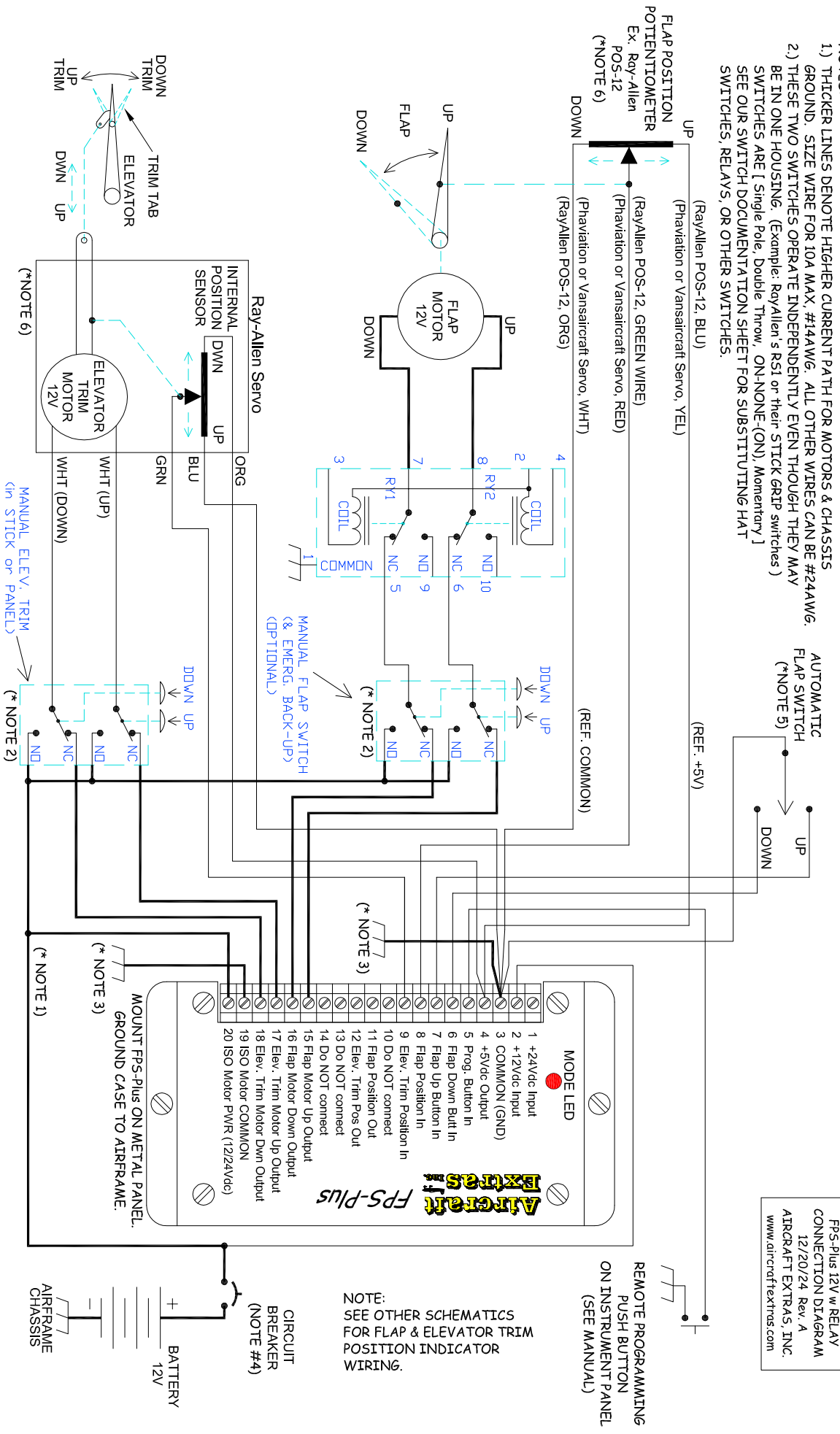

FPS-Plus 12V w RELAY CONNECTION DIAGRAM
12/20/24 Rev. A
AIRCRAFT EXTRAS, INC.
www.aircraftextras.com

REMOTE PROGRAMMING PUSH BUTTON ON INSTRUMENT PANEL (SEE MANUAL)

NOTE: SEE OTHER SCHEMATICS FOR FLAP & ELEVATOR TRIM POSITION INDICATOR WIRING.

- NOTES:
- 3.) SEPARATE LARGER WIRE TO CHASSIS. (#18AWG to #10AWG)
 - 4.) WE RECOMMEND A PUSH-ON/PULL-OFF BREAKER. SIZE CIRCUIT BREAKER FOR MAX. MOTOR CURRENTS UP TO 10A.
 - 5.) ANY SWITCH [Single Pole, Double Throw, (ON)-OFF-(ON), Momentary] WE DO NOT RECOMMEND MOUNTING THIS SW ON STICKS SINCE ACCIDENTALLY BUMPING THIS SWITCH ACTIVATES A SIGNIFICANT FLAP MOVEMENT.
 - 6.) POTENTIOMETERS CAN BE 5K, 10K, or 20K Ohms. (Ex: model: RayAllen's POS-12) (FOR ELEV. TRIM, YOU CAN USE THE INTERNAL POT THAT IS A PART OF RayAllen's SERVO IF DESIRED.)
 - 7.) ALL SWITCHES AND RELAYS SHOWN IN THEIR DE-ENERGIZED CONDITION.

SCHEMATIC (FPS-Plus for +24V Systems)

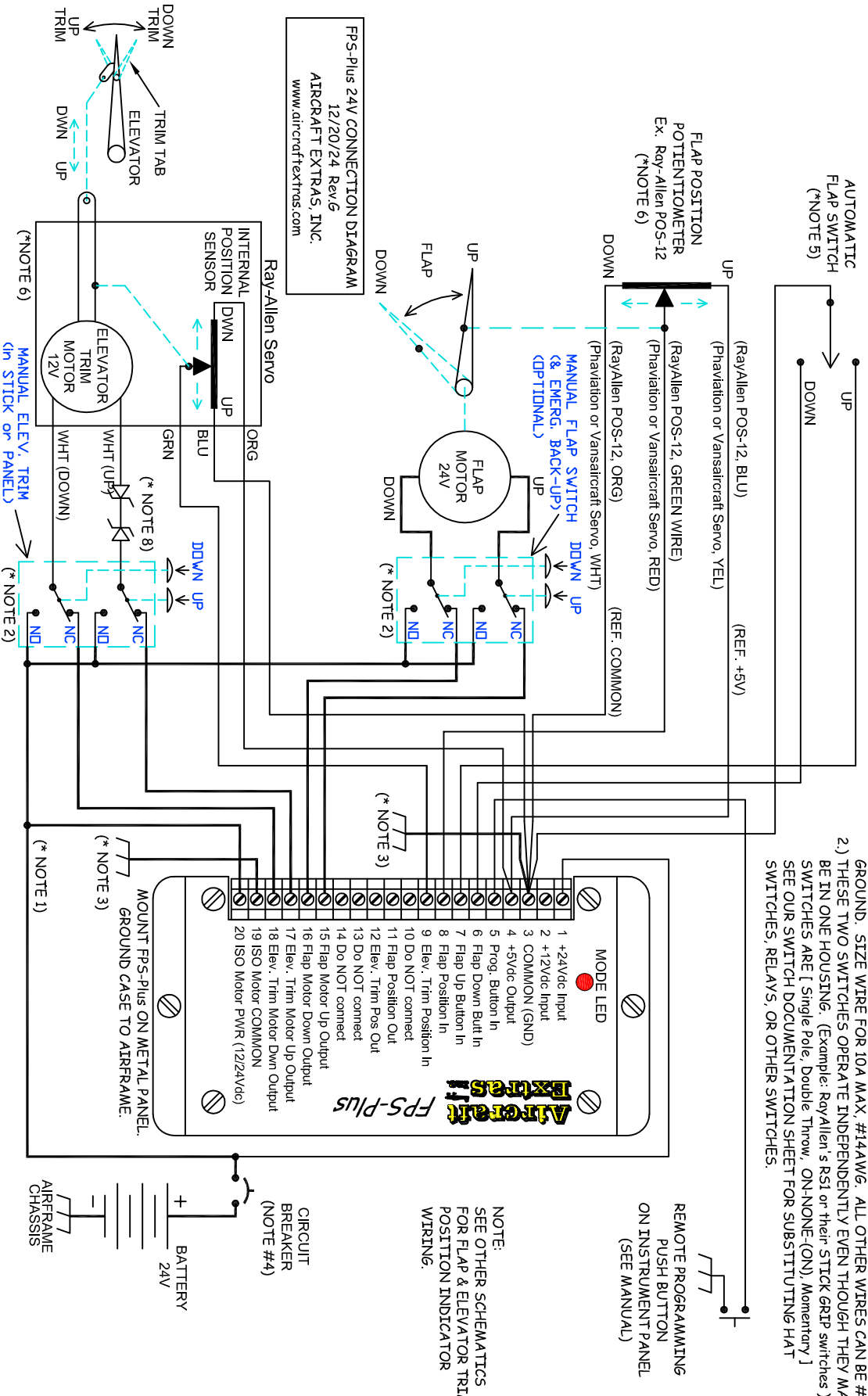

- NOTES:
- 1.) THICKER LINES DENOTE HIGHER CURRENT PATH FOR MOTORS & CHASSIS GROUND. SIZE WIRE FOR 10A MAX, #14AWG. ALL OTHER WIRES CAN BE #24AWG.
 - 2.) THESE TWO SWITCHES OPERATE INDEPENDENTLY EVEN THOUGH THEY MAY BE IN ONE HOUSING. (Example: RayAllen's RSI or their STICK GRIP switches) SWITCHES ARE [Single Pole, Double Throw, ON-NONE-(ON) Momentary] SEE OUR SWITCH DOCUMENTATION SHEET FOR SUBSTITUTING HAT SWITCHES, RELAYS, OR OTHER SWITCHES.

- NOTES:
- 3.) SEPARATE LARGER WIRE TO CHASSIS. (#18AWG to #10AWG)
 - 4.) WE RECOMMEND A PUSH-ON/PULL-OFF BREAKER. SIZE CIRCUIT BREAKER FOR MAX. MOTOR CURRENTS UP TO 10A.
 - 5.) ANY SWITCH [Single Pole, Double Throw, (ON)-OFF-(ON), Momentary] WE DO NOT RECOMMEND MOUNTING THIS SW ON STICKS SINCE ACCIDENTALLY BUMPING THIS SWITCH ACTIVATES A SIGNIFICANT FLAP MOVEMENT.
 - 6.) POTENTIOMETERS CAN BE 5K, 10K or 20K Ohms. (Ex. model: RayAllen's POS-12) (FOR ELEV. TRIM, YOU CAN USE THE INTERNAL POT THAT IS A PART OF RayAllen's SERVOS IF DESIRED.)
 - 7.) ALL SWITCHES ARE SHOWN IN THE DE-ENERGIZED STATE.
 - 8.) TO USE RayAllen 12V SERVOS OR 12V ELEV. TRIM MOTORS, USE 1N5349A ZENER DIODES FOR MOTORS THAT DRAW LESS THAN 0.4A. TO USE 24V MOTORS, DO NOT USE THE ZENERS, SIMPLY WIRE UP STRAIGHT.

SCHEMATICS (FPS-Plus-nt Position Indicator Connection)

for Analog or EFIS Indicators

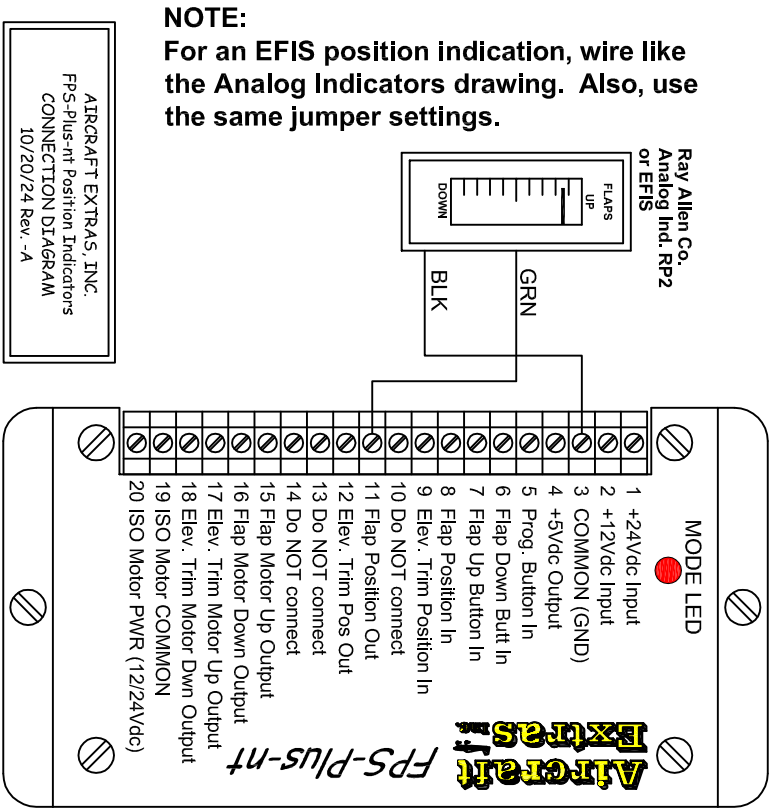

NOTE:
For an EFIS position indication, wire like the Analog Indicators drawing. Also, use the same jumper settings.

for Digital Indicators

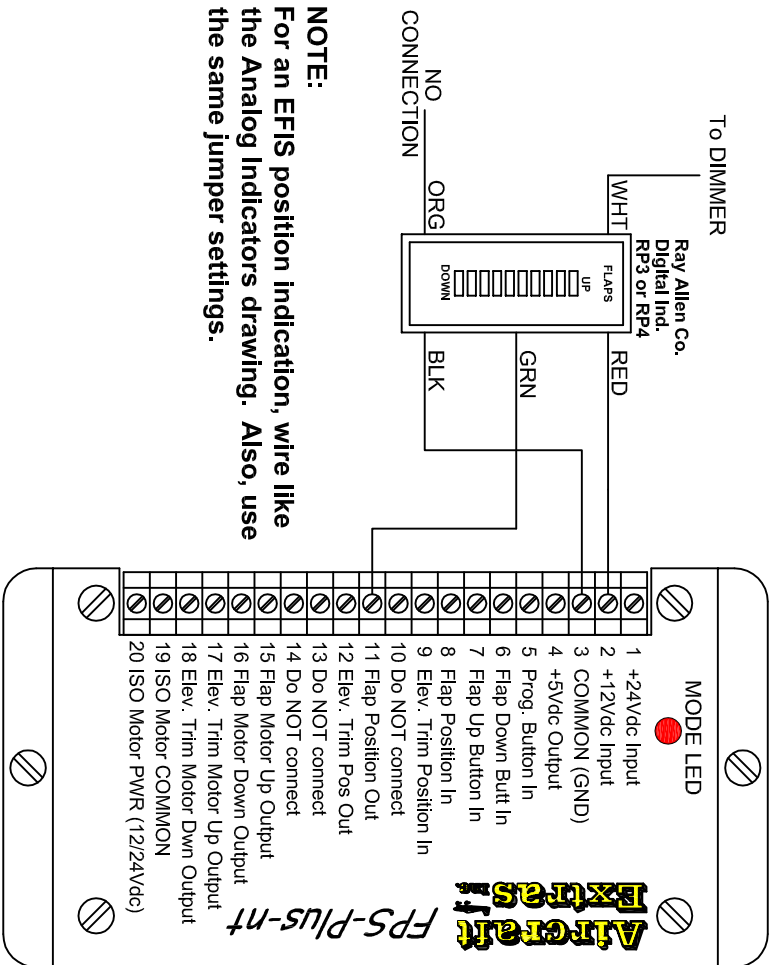

- NOTES:**
- 1.) IT MIGHT BE HELPFUL TO WIRE THE FPS-Plus-nt TO THE +12V or +24V DIAGRAMS BEFORE WIRING THE FLAP POSITION INDICATOR.
 - 2.) OTHER OUTPUT SCALINGS ARE POSSIBLE TO INTERFACE WITH DIFFERENT POSITION INDICATORS. PLEASE CONSULT FACTORY.

Switching Options & Background knowledge

SW1

Single Pole, Double Throw
ON-NONE-ON
2 Positions

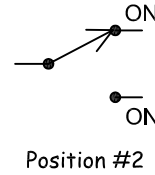
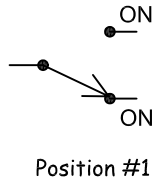

SW2

Single Pole, Double Throw
(ON)-OFF-(ON)
3 Positions
(Switch is a momentary on switch)

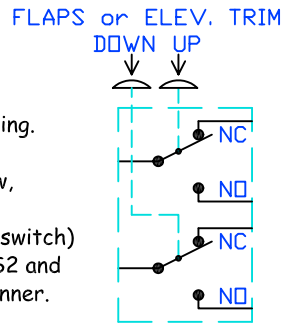
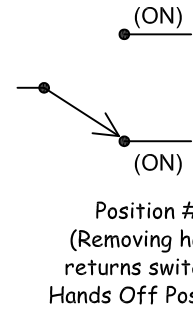
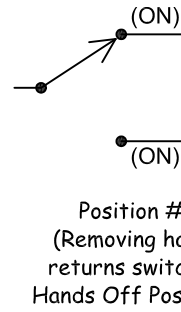
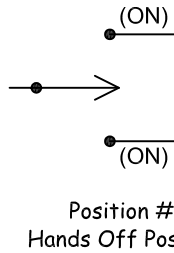

This diagram depicts 2 switches in one housing.
Each switch is operated independently.
Each switch is a Single Pole, Double Throw, ON-NONE-(ON), 2 Position switch.
(Each switch is a spring loaded "momentary on" switch)
The RayAllen Company stick grips and their RS2 and RS2-5 panel switches can be wired in this manner.

Figure 1

NOTE:

IF YOU DO NOT HAVE 2 INDEPENDENT SWITCHES THAT YOU CAN WIRE LIKE FIGURE #1, YOU CAN OBTAIN THIS SAME SWITCHING ACTION BY USING A STANDARD SWITCH (SW2 as pictured above) WITH OUR RELAY BOARD (1RY1). SEE THE DIAGRAM ABOVE. THE RELAY BOARD ARCING PROTECTION CIRCUITRY WAS OMITTED FROM THIS DIAGRAM FOR SIMPLICITY. IF YOU DESIRE TO ADD A SWITCH FOR THE CO-PILOT OR TO ANOTHER PANEL LOCATION, YOU MAY ACHIEVE THIS BY SIMPLY PARALLELING SEVERAL SWITCHES FOR SW2.

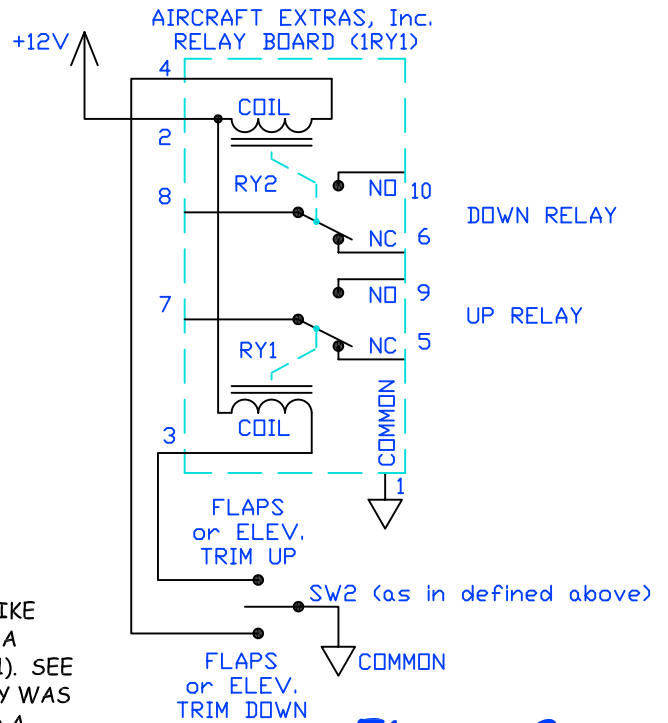

Figure 2

GENERAL NOTES:

- 1.) FOR SWITCHES, (ON) MEANS "ON MOMENTARY" OR SPRING LOADED.
- 2.) FOR RELAYS, NO = NORMALLY OPEN, NC = NORMALLY CLOSED WHEN DE-ENERGIZED.
- 3.) ALL RELAYS AND SWITCHES ARE SHOWN IN THE DE-ENERGIZED STATE.

**Aircraft
Extras Inc.**

SWITCHING OPTIONS DIAGRAM
Rev. - A, 11/1/07
AIRCRAFT EXTRAS, INC.
www.aircraftextras.com